

# MIMO Communication Systems Modeling and Simulation in Capsim



***Silicon DSP Corporation***

© 2007-2018 Silicon DSP Corporation, Las Vegas, Nevada, All Rights Reserved

# 2x3 MIMO OFDM System

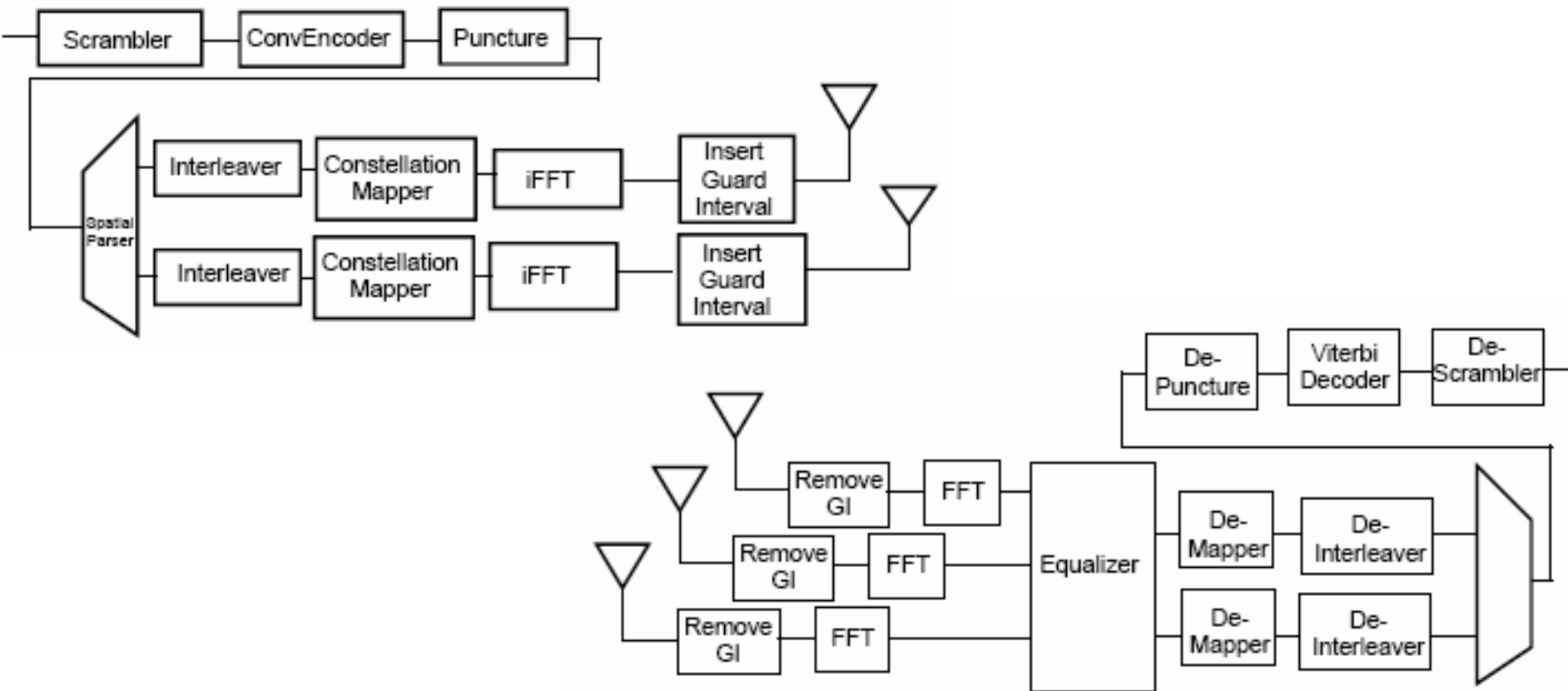

# Capsim 2x3 MIMO System

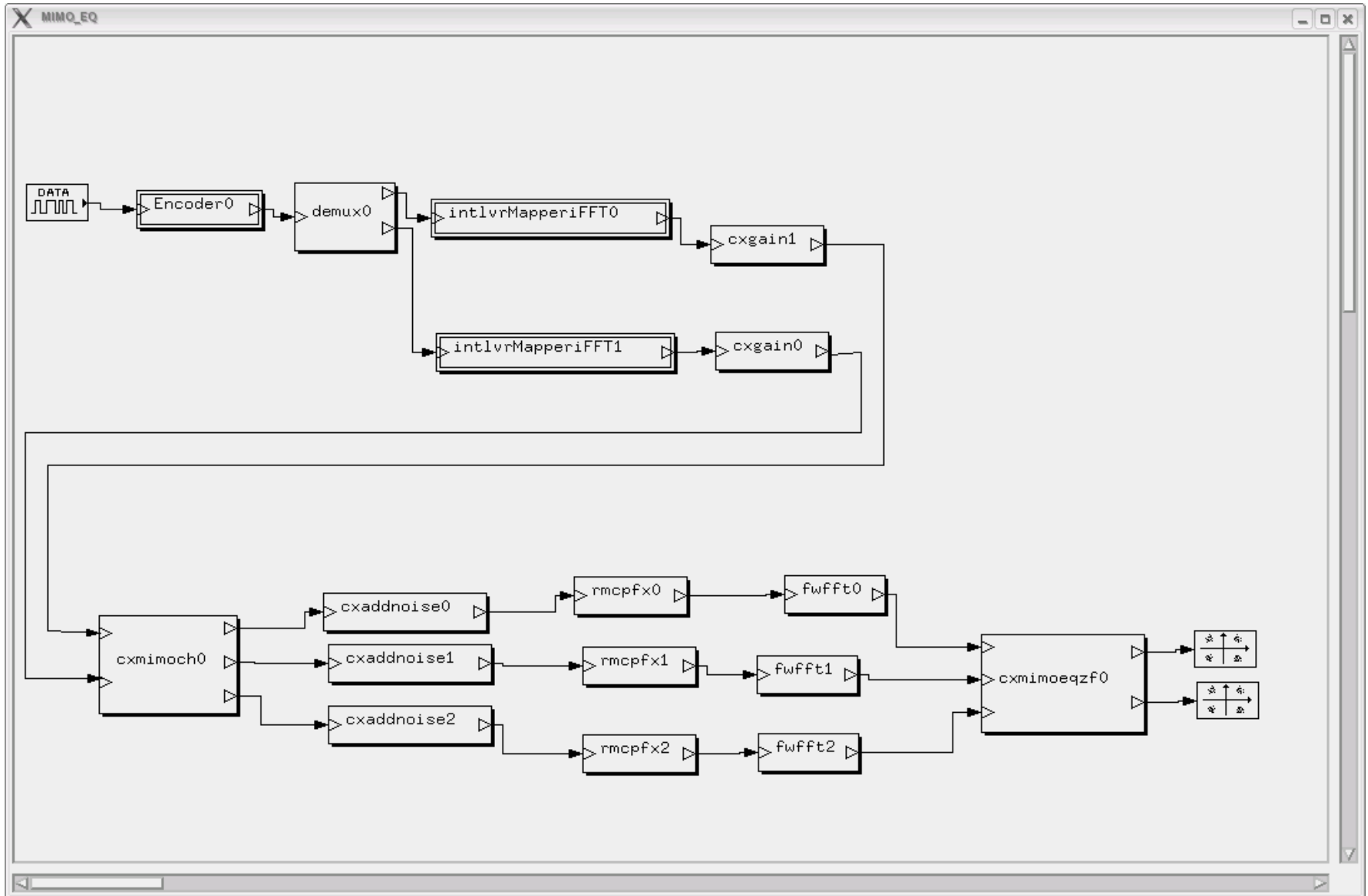

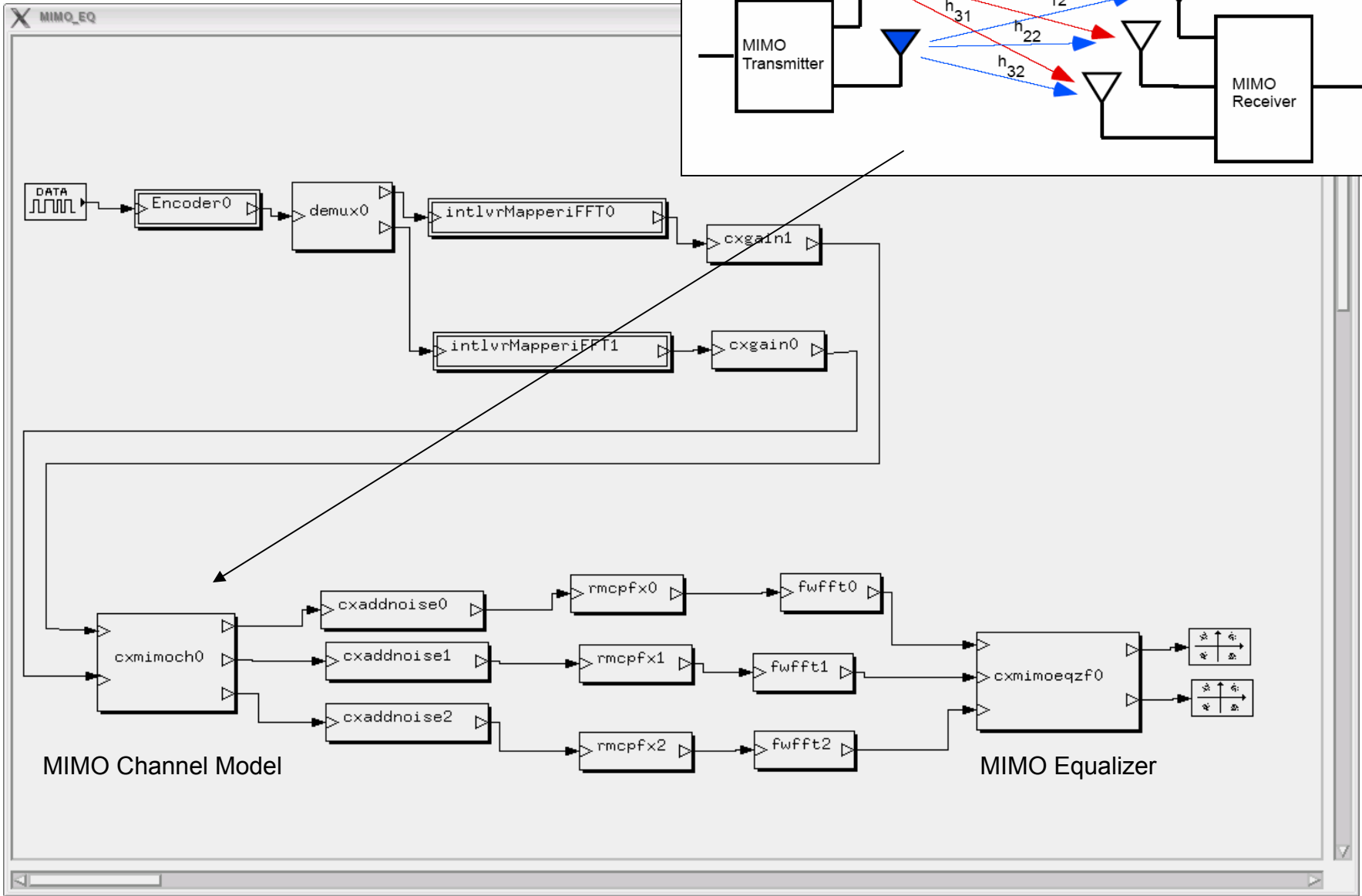
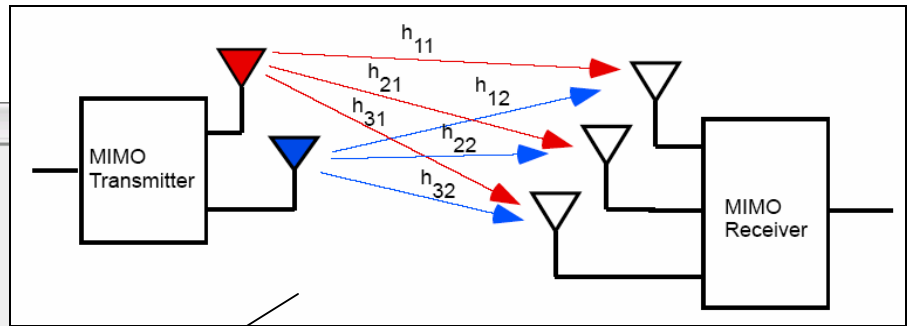

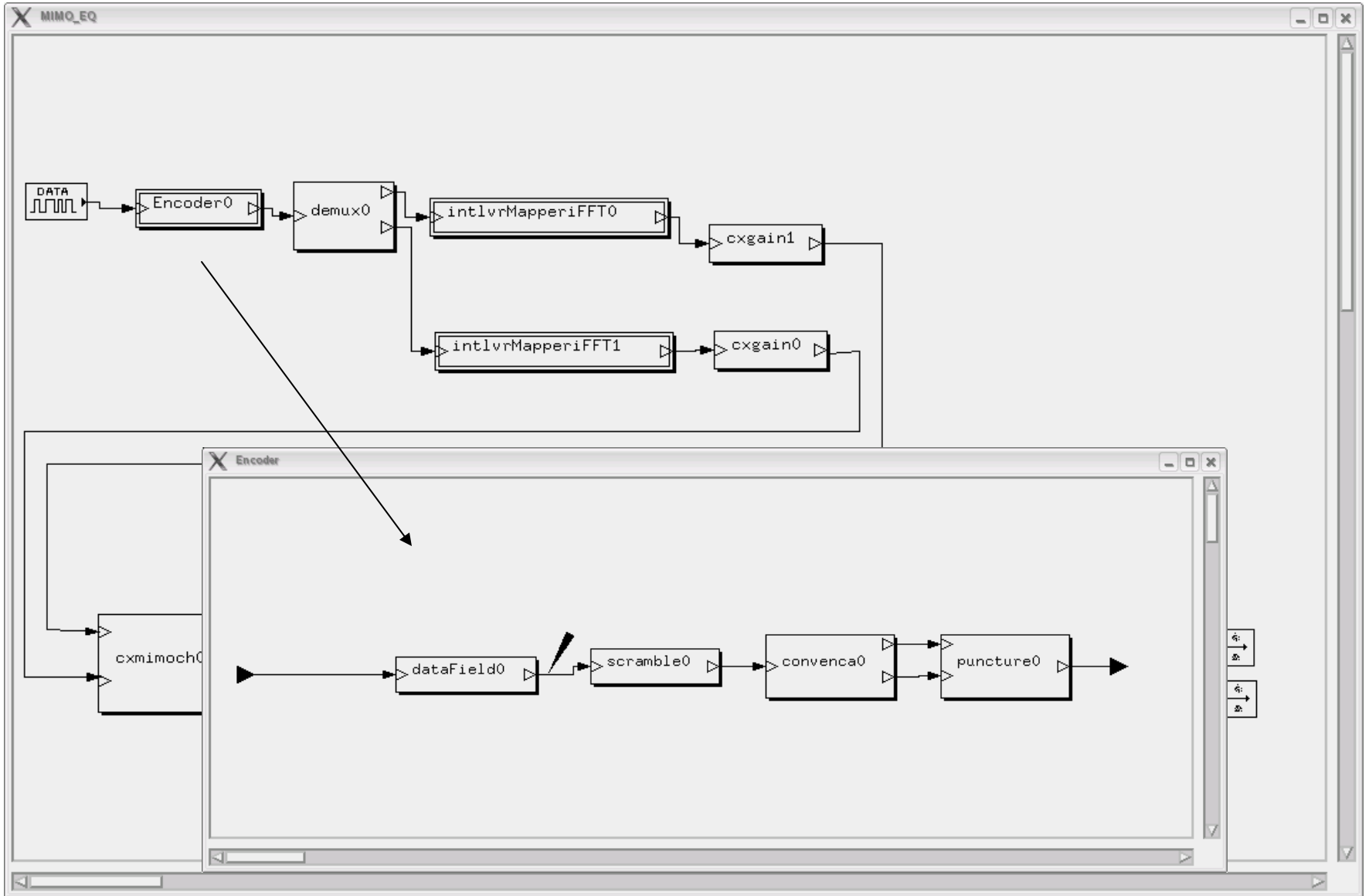

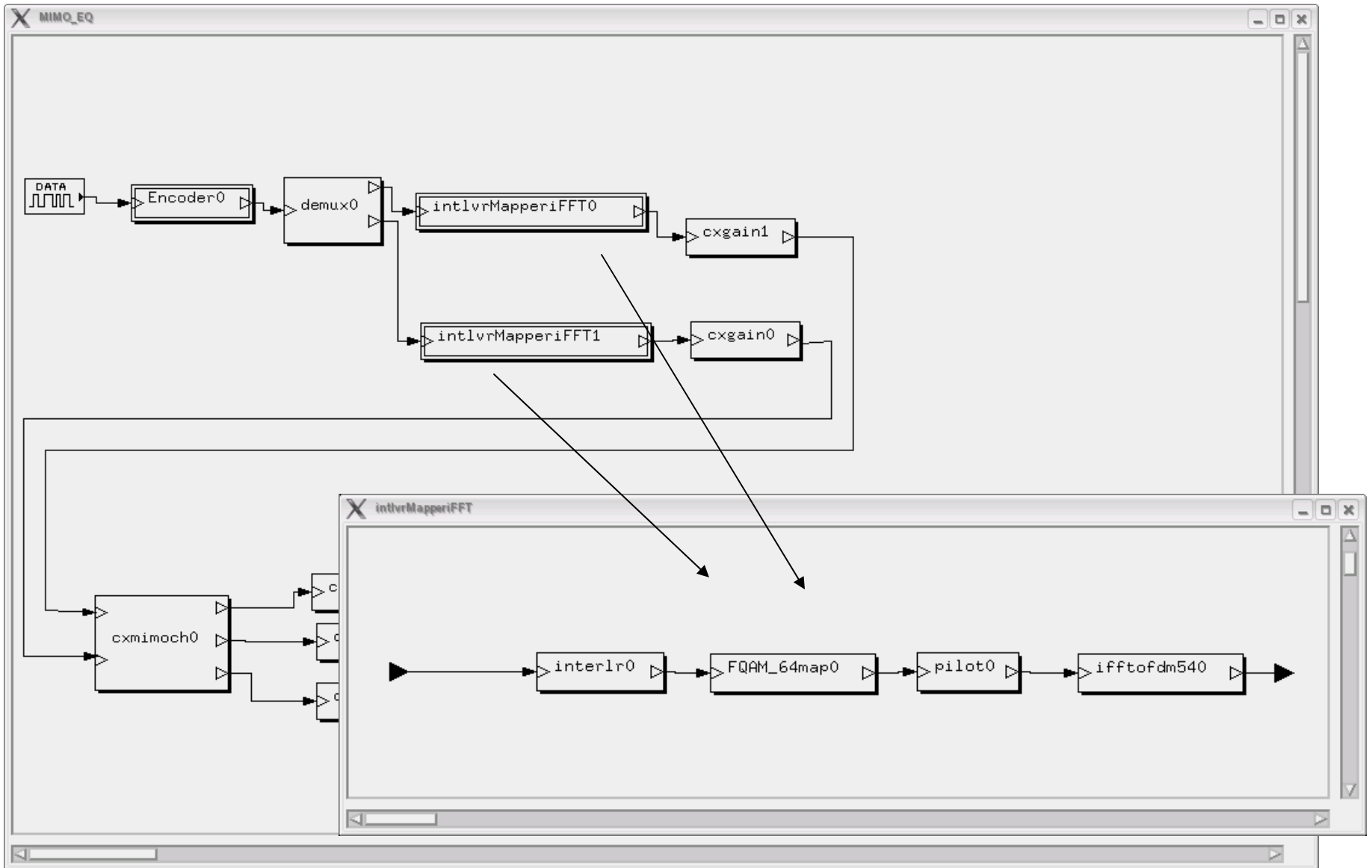

# Capsim 2x3 MIMO System

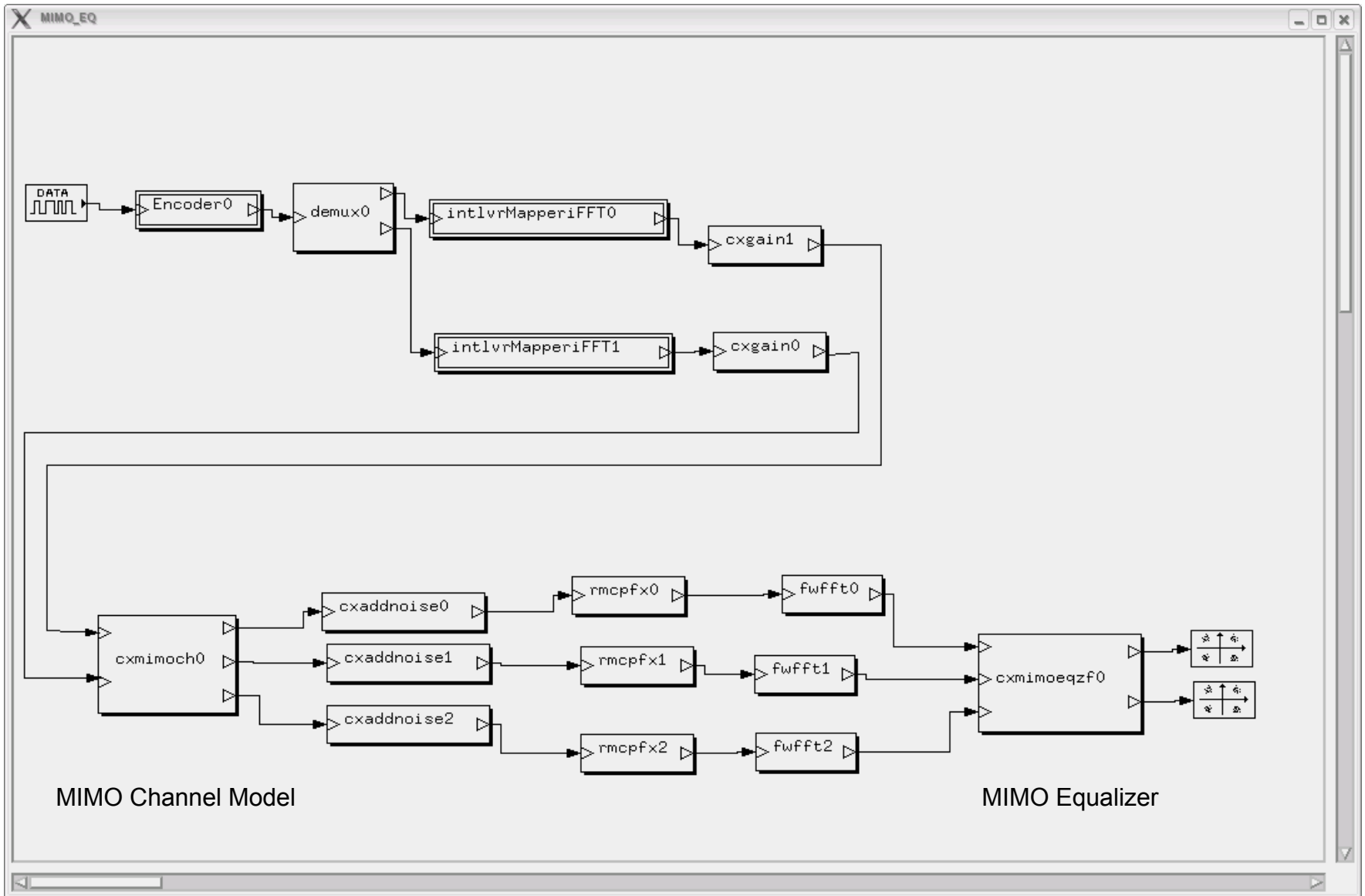

# Capsim 2x2 MIMO System

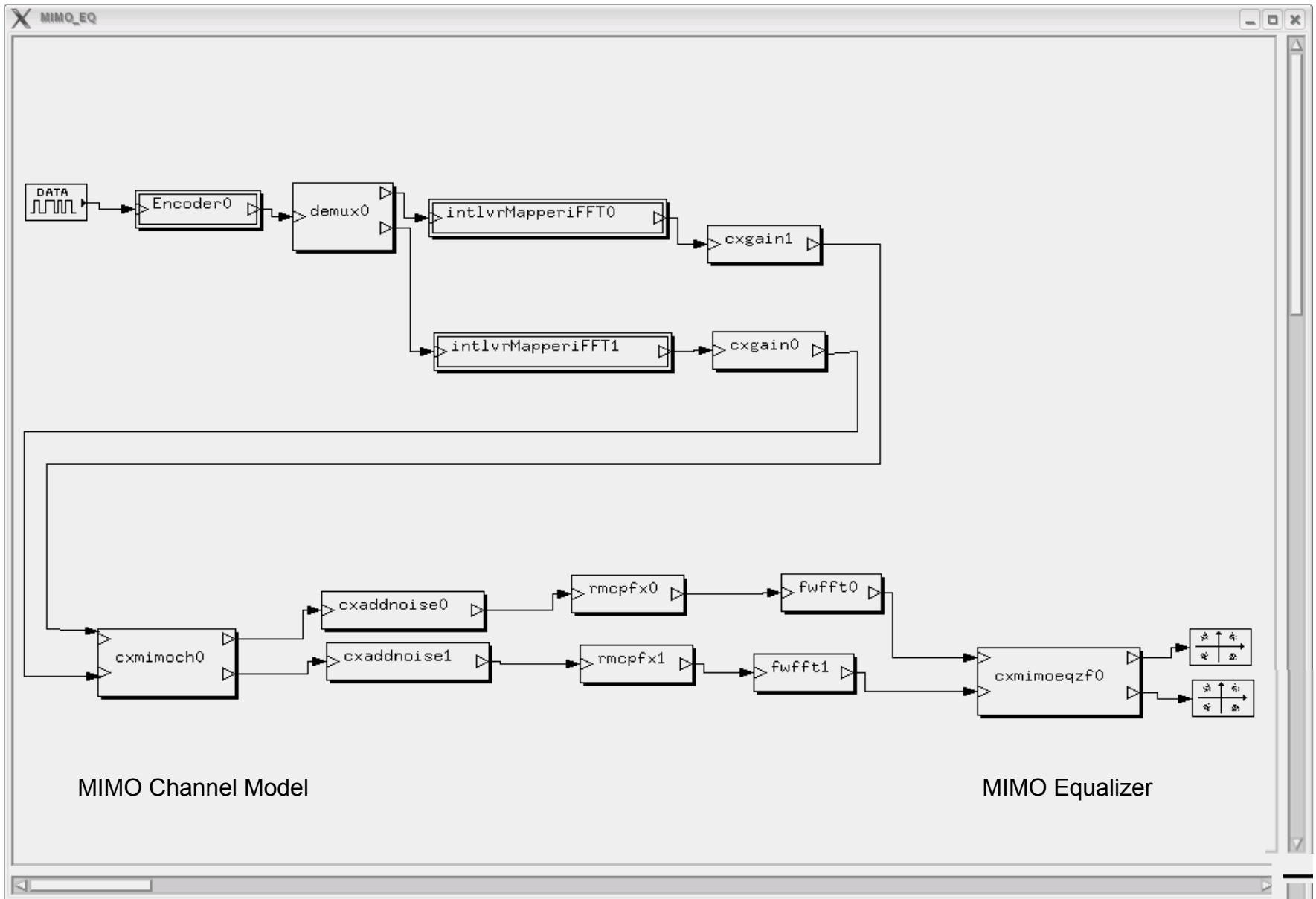



# 2x2 Strong Weak

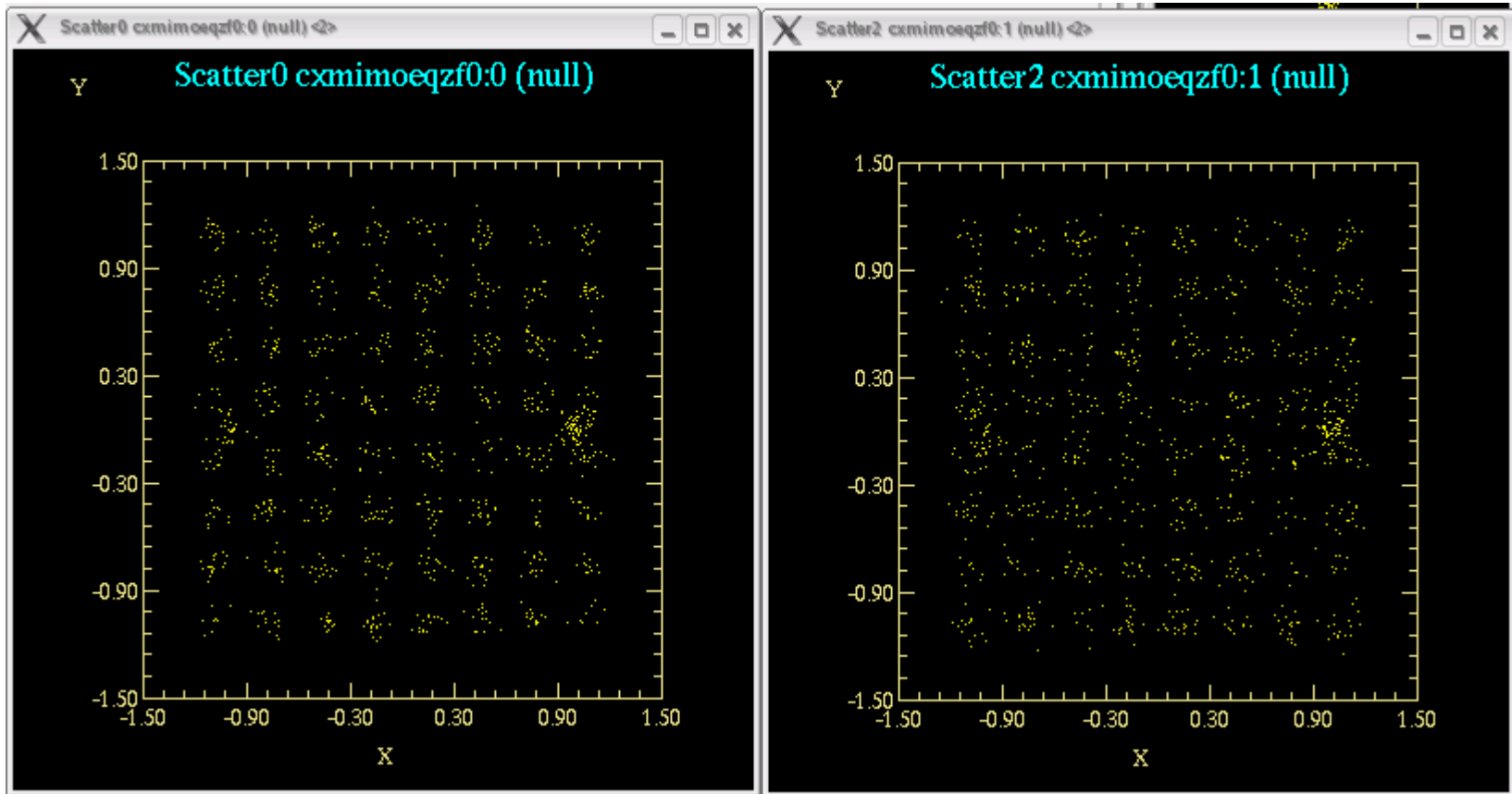

# 2x3 Strong Weak

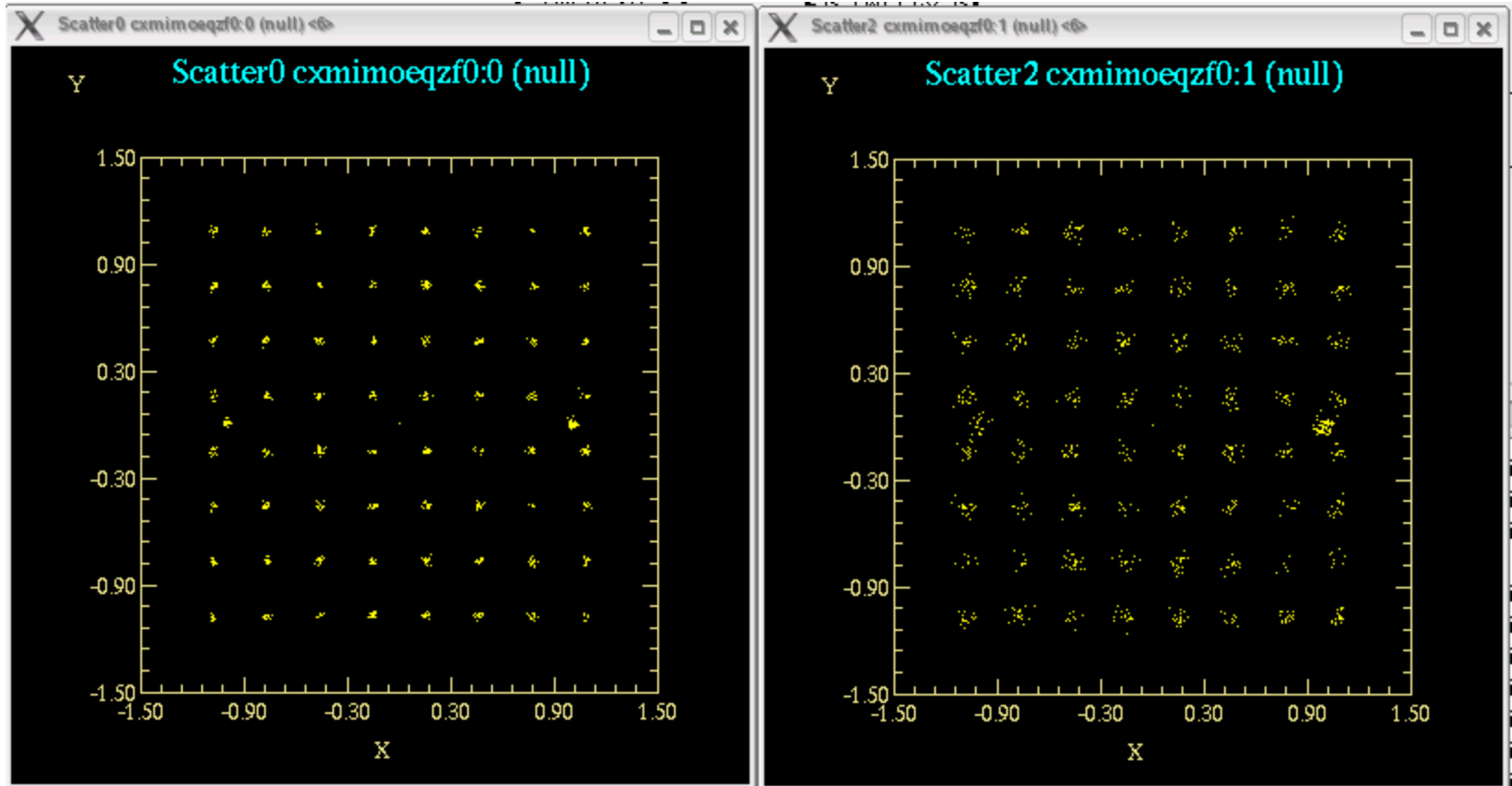

# 2x3 Equal

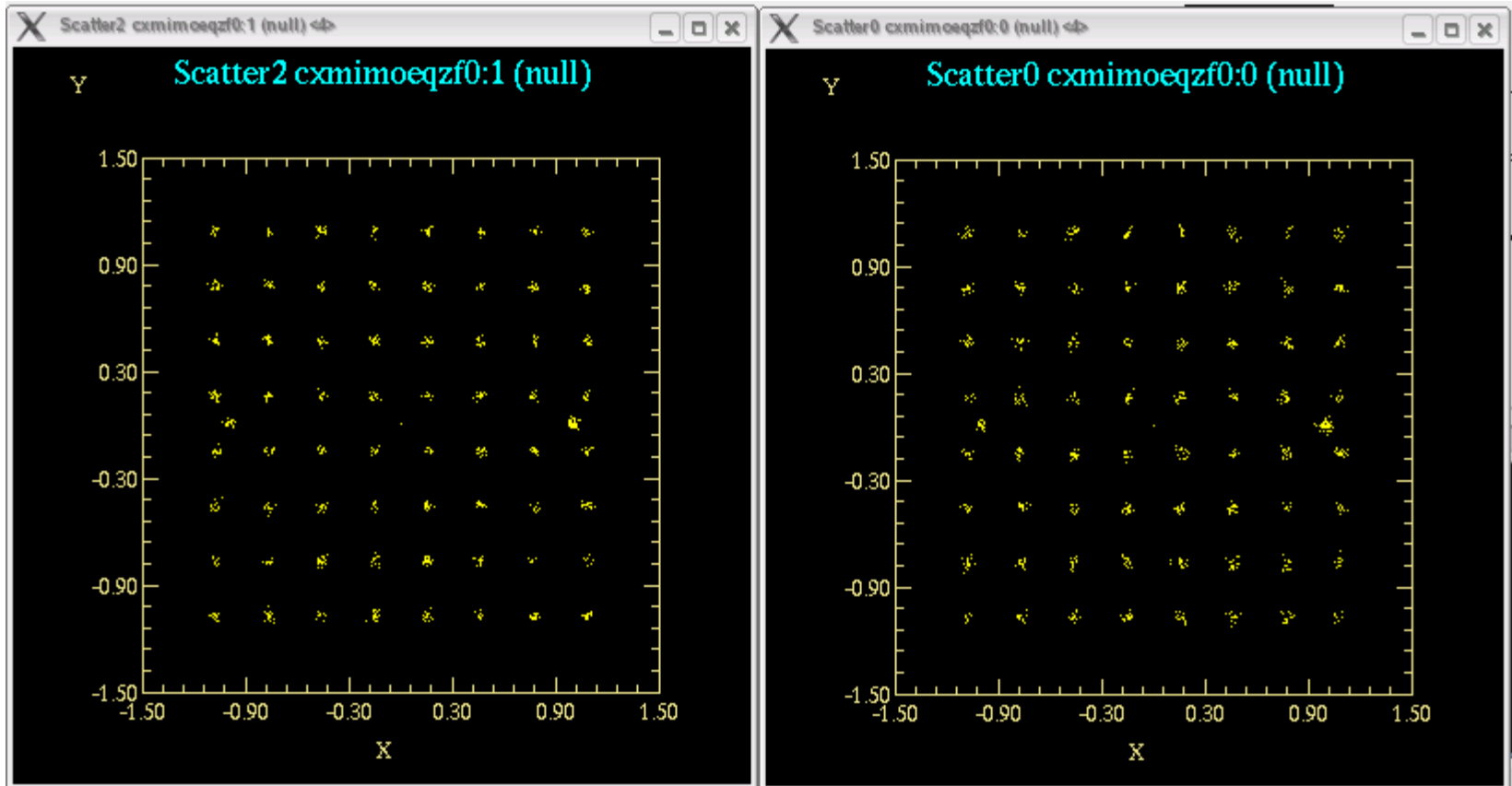

# 2x3 Strong Weak

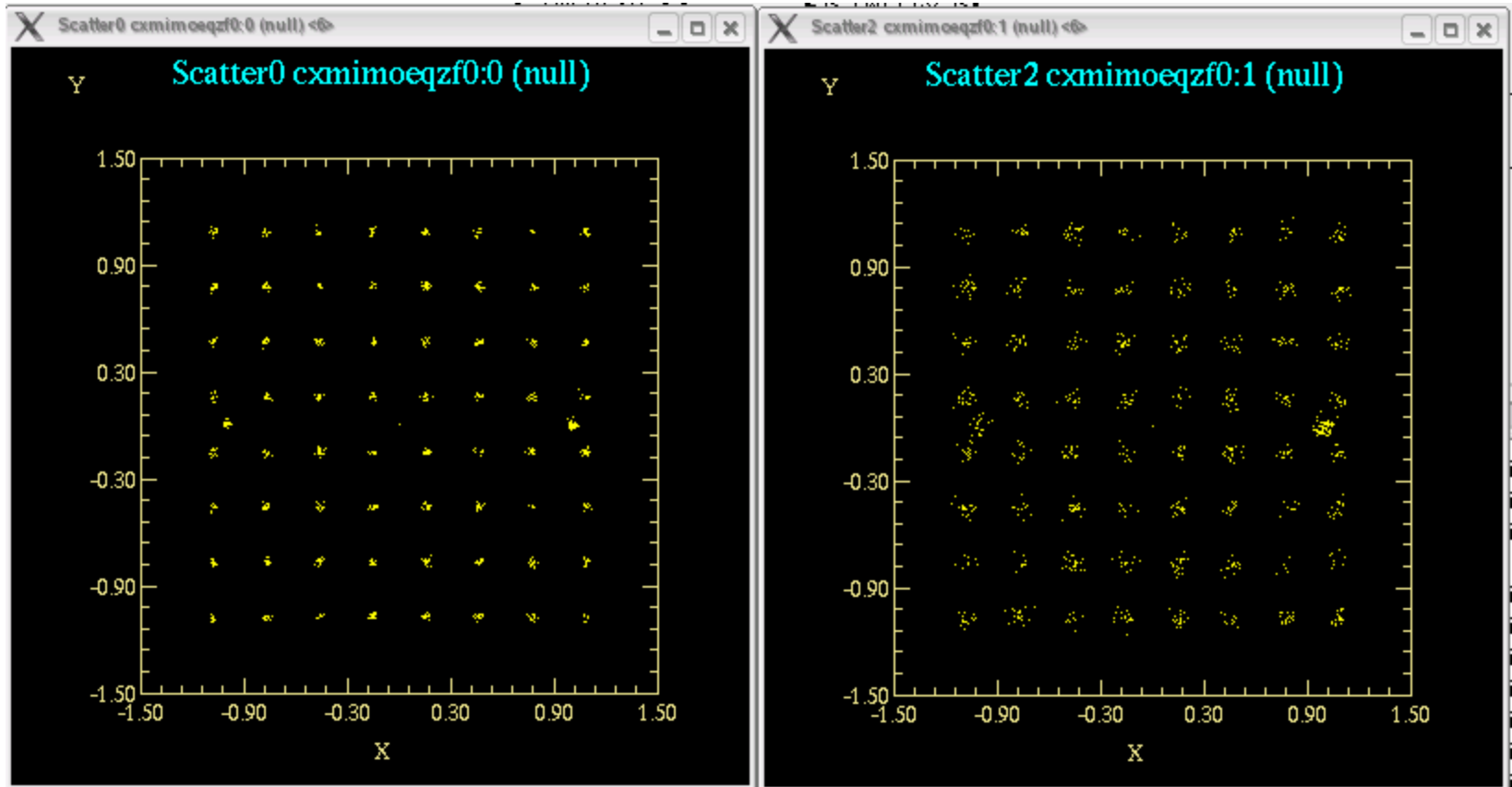

# SISO

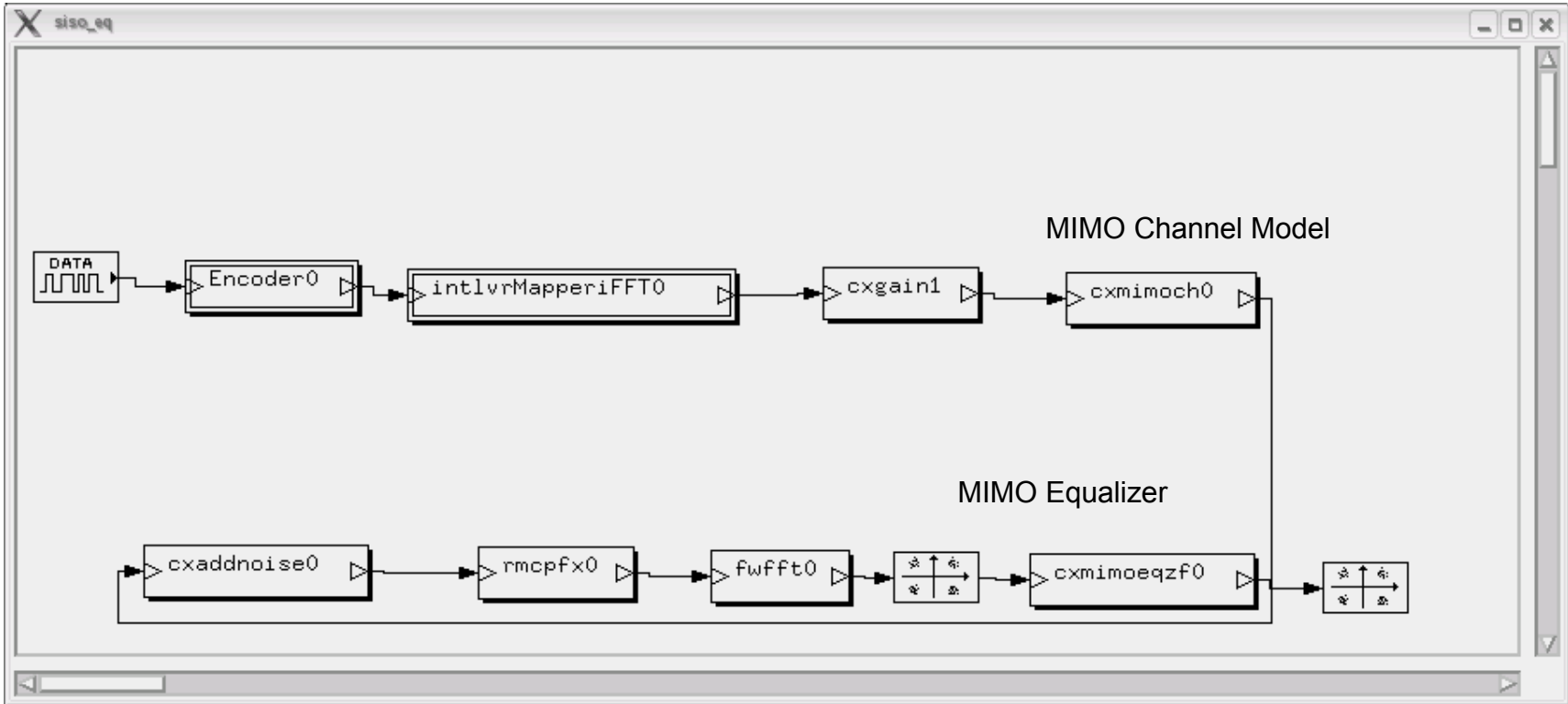

# MRC

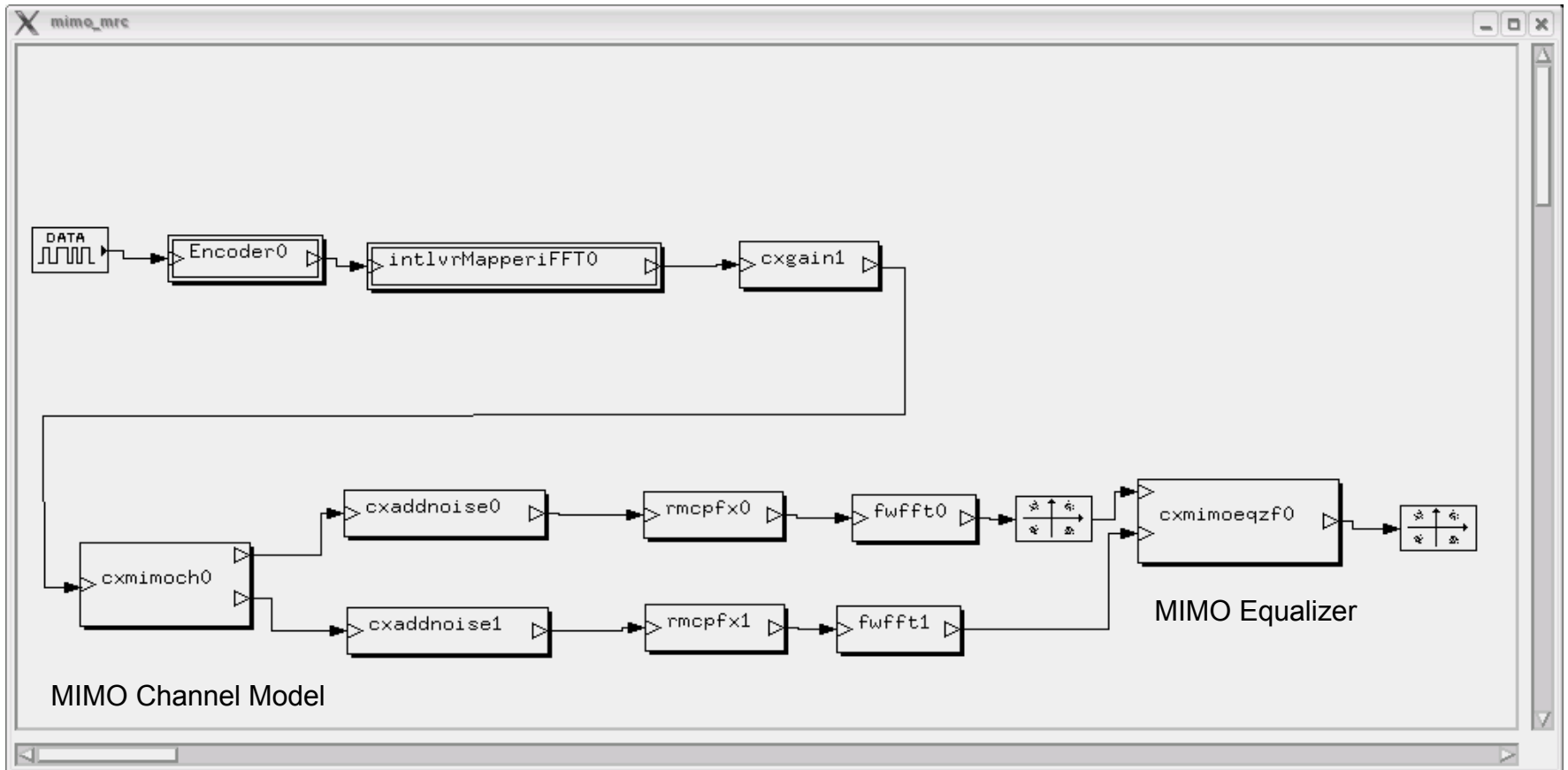

# SISO versus MRC

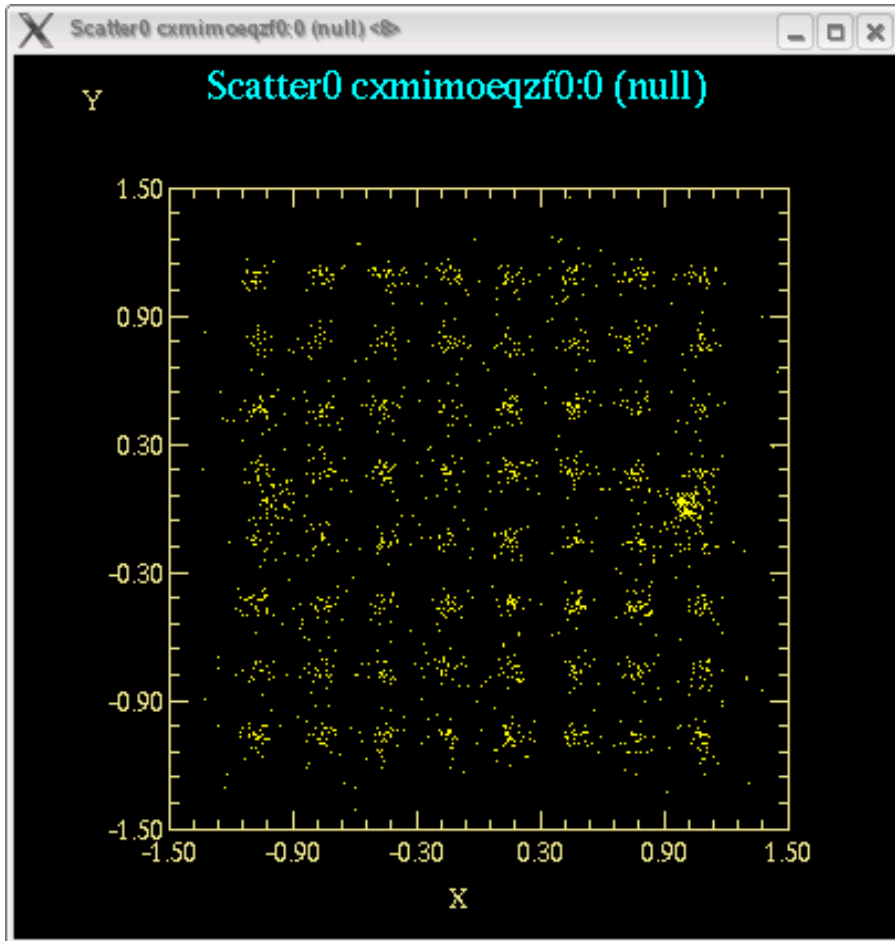

SISO

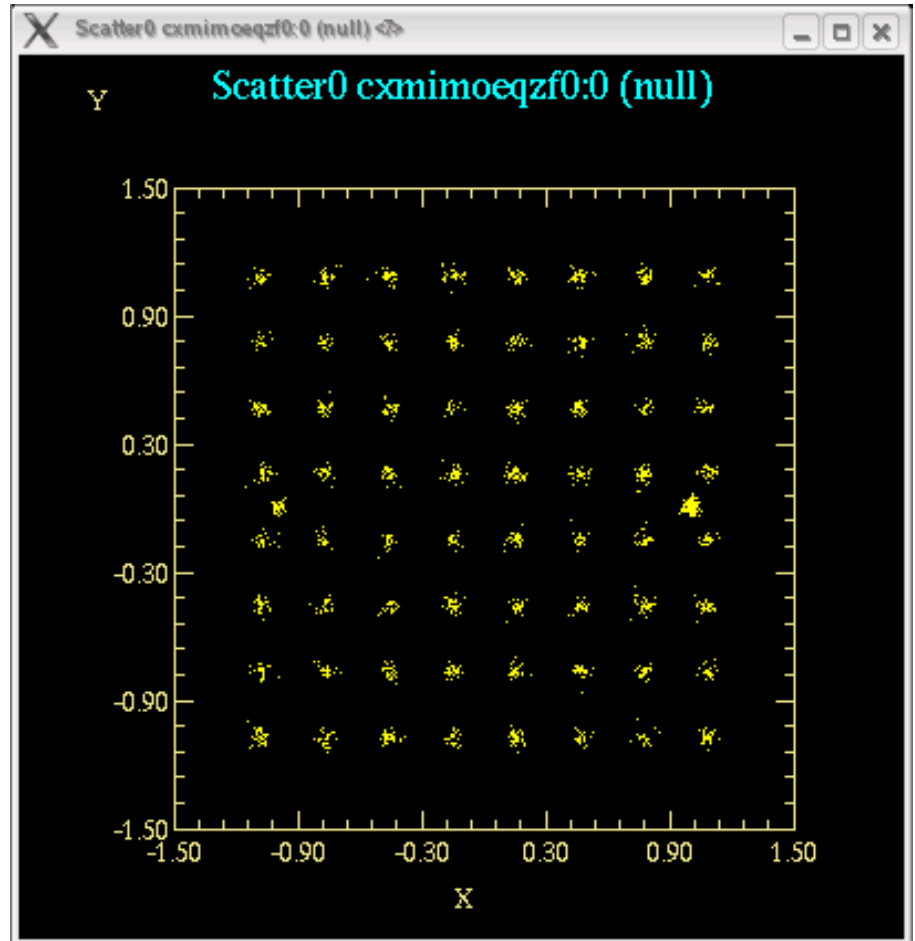

MRC

